

**Maße / Dimensions**  
**Schieber Serie AT 100 mit Zylinder**  
**Knife gate valve series AT 100**  
**with pneumatic cylinder**  
**DN 80 - DN 200**

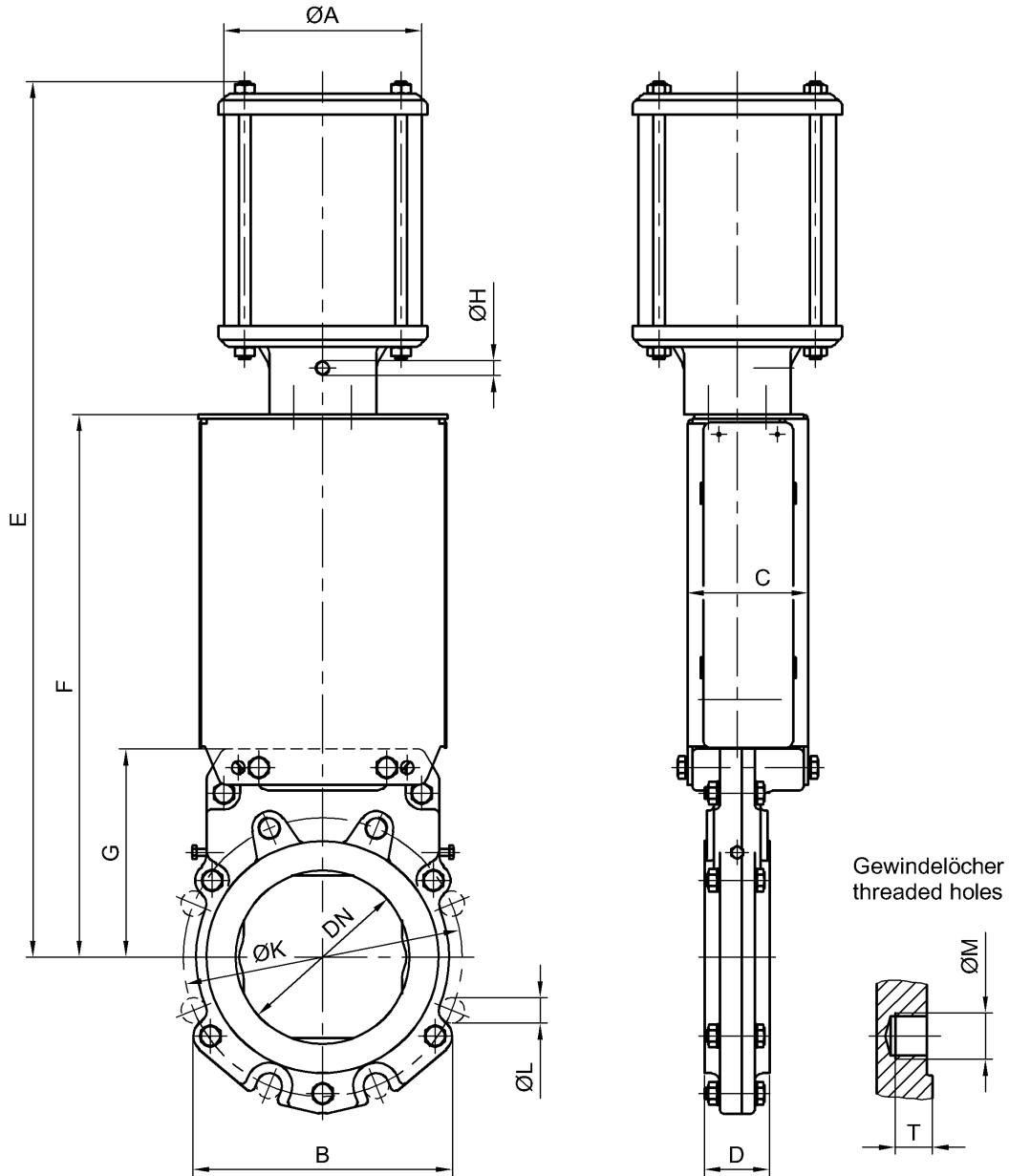

DN	NPS	P <sub>D</sub>	ØA	B	C	D	E	F	G	ØH	ØK	ØL	ØM	T	kg
80	3"	8	80	139	91	46	455	270	128	R1/4"	160	6xØ18	2xM16	16	12
100	4"	8	100	164	96	52	547	335	138	R1/4"	180	6xØ18	2xM16	20	14
125	5"	5	100	191	96	56	590	353	155	R1/4"	210	6xØ18	2xM16	22	16
150	6"	6	160	223	104	56	753	467	179	R1/4"	240	6xØ22	2xM20	21	27
200	8"	5	160	301	104	60	833	497	209	R1/4"	295	6xØ22	2xM20	23	32

P<sub>D</sub> [bar] = max. Differenzdruck bei Betätigung / max. differential pressure during operation

Steuerdruck für Zylinder / air pressure for cylinder: 6 bar

Max. Betriebsdruck:  
 Max. working pressure:

DN	Druck / pressure
80-150	10 bar
200	6 bar

Änderungen vorbehalten  
 subject to changes