

1. General information

- 1.1 Maintenance work may only be carried out by qualified and authorised people.
- 1.2 Routine valve maintenance is not necessary. However, the spindle (piston rod in the case of pneumatic or hydraulic cylinders) must always be well greased and free of soiling.
- 1.3 In the event of a minor leak where the plate passes through, this can usually be eliminated by resealing (see "General Operating Instructions"). If the leak cannot be stopped in this way, complete sealing replacement must take place. We recommend having the manufacturer carry out the sealing replacement.
- 1.4 The following special tools are required for sealing replacement:
 - Packing tool
 - Suitable cutting tools (scissors, sanding disc)
 - Suitable retaining fixtures (e.g. metal clamps) as a mounting aid for cross-sealing and scraper

2. Spare parts

- 2.1 Only original spare parts may be used.
- 2.2 For complete sealing replacement, the following spare parts are required:
 - Cross-sealing (compact cross-sealing, cross-sealing with scraper or U-profile (PTFE) with silicone base)
 - Suitable grease (e.g. Red Rubber)
 - Round seal
 - Ductile seal rhombic
 - Ductile seal round (Ø4mm)

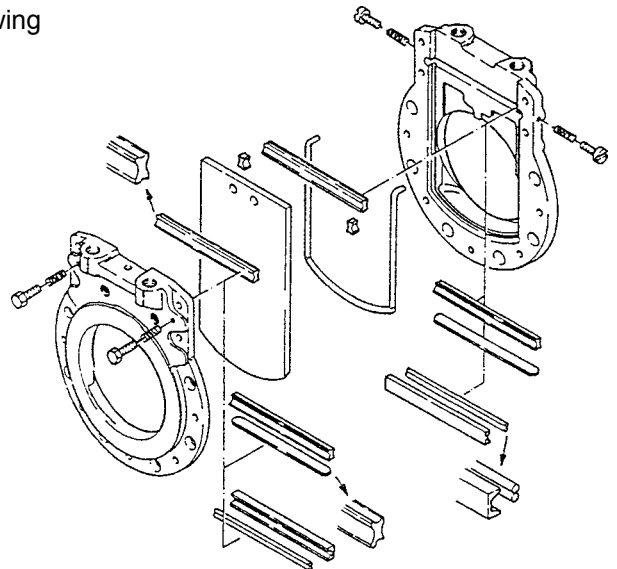

3. Dismantling and cleaning

For complete sealing replacement, the valve must be removed from the pipeline.

- Check that the pipeline has been depressurised and emptied.
- Loosen the connections (electrical and pneumatic).
- Remove operating element.
- Loosen and remove the flange screws.
- Spread the flanges using a suitable tool and remove the valve and the seals.
- Loosen the screw fastening on the two halves of the housing and set the housing parts down on the side with the flange sealing surface.
- Remove the old sealing material and clean the sealing areas thoroughly.

4. Preparing the front body part

- 4.1** Cut the **cross-sealing** (if appropriate scraper or base as well) a sealing to the groove length.

Make the narrow ends of the sealing fit the shape of the groove radii using a suitable tool (e.g. scissors or sanding disc).

Lay the compact cross-sealing in the cross-sealing groove and grease it using a suitable agent (e.g. Red Rubber).

The narrower side must be pointing towards the gate!

If a scraper is used in combination with the compact cross-sealing proceed as shown on the right.

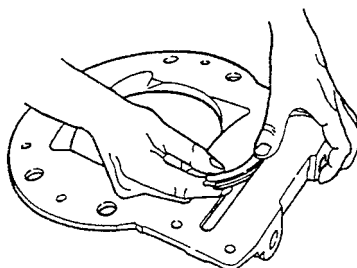
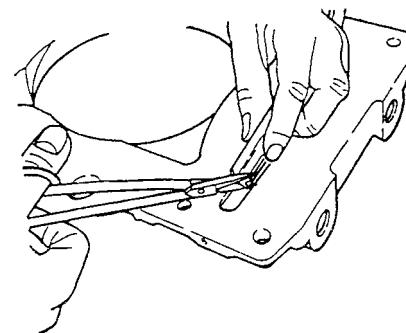

If a U-profile (PTFE) with silicone base is used, proceed as shown below.

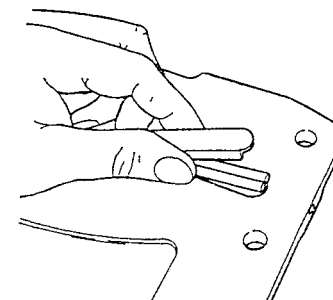
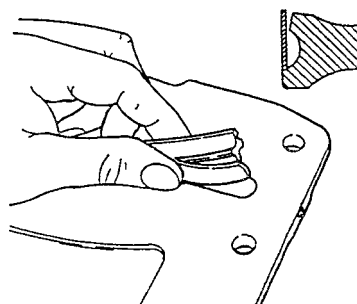

- 4.2** Fix the sealing elements in place using a suitable retaining fixture (e.g. metal clamps).

5. Preparing the rear body part

- 5.1** Adapt and insert the **cross-sealing** (if appropriate scraper or base as well) as described for the front body part.

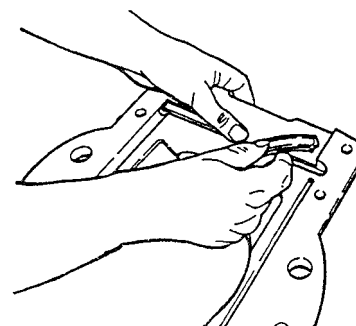

- 5.2** Determine the length of the round seal by trial and error, inserting it in the groove planned for it and cut it off around 5-10 mm longer. (In its installed position, the sealing should be slightly upset).

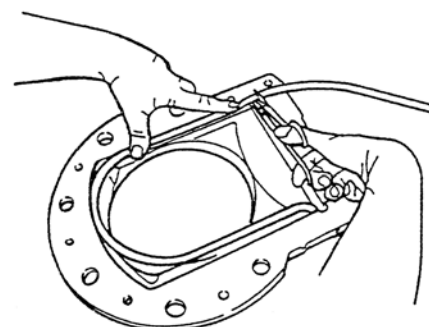

Insert the round seal in the bore holes below the cross-sealing groove.
Sharpen the ends of the round seal if necessary for this.

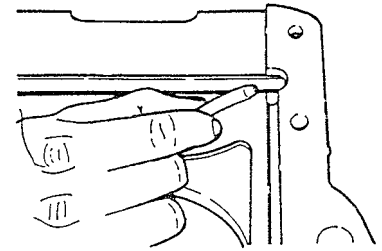

5.3 Insert the gate in such a way that the chamfer is pointing downwards.

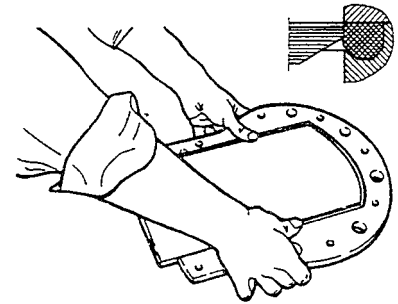

5.4 Push the round seal into the intended groove and grease using a suitable agent (e.g. Red Rubber).

Push the gate forwards using a plastic hammer or similar.

The inserted round seal should now have 1 mm pre-tension.

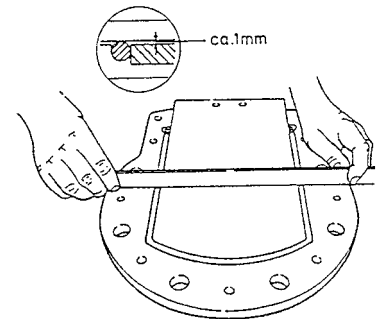

Correct pressing by backing the round seal if necessary.

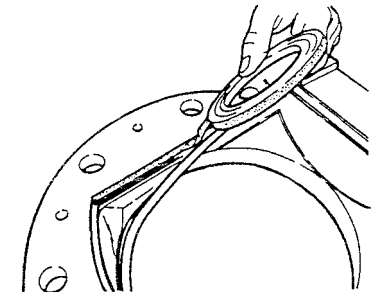

5.5 Fill the two indentations next to the gate at the level of the cross-sealing profile using filling corner profiles (= cross-sealing profile). The length measurement depends on the thickness of the plate and this should be 0.5 – 1mm less than this.

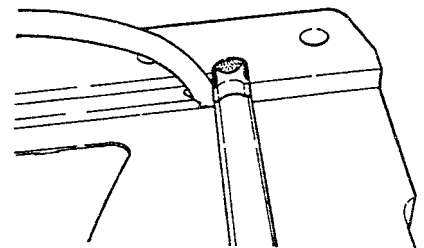

Fill the remaining **intermediate spaces** with rhombic ductile seal.

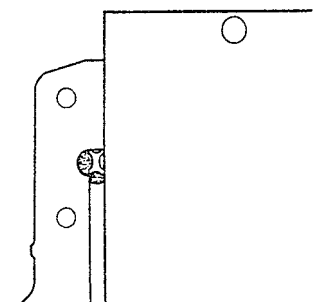

6. Mounting the halves of the housing

- 6.1** Place the front body part on the prepared rear body part.
- 6.2** Remove the retaining fixture.
The front body part and the rear body part must be in true alignment.
- 6.3** Tighten the housing screws at the specified torque. Keep the prescribed order of tightening (see diagram).

DN:	Screw-Ø:	Torque [Nm]:
50 – 80	M8	17
100 – 250	M10	27
300 – 350	M12	39
400 – 800	M16	75
900 – 1000	M20	117
1200	M24	169

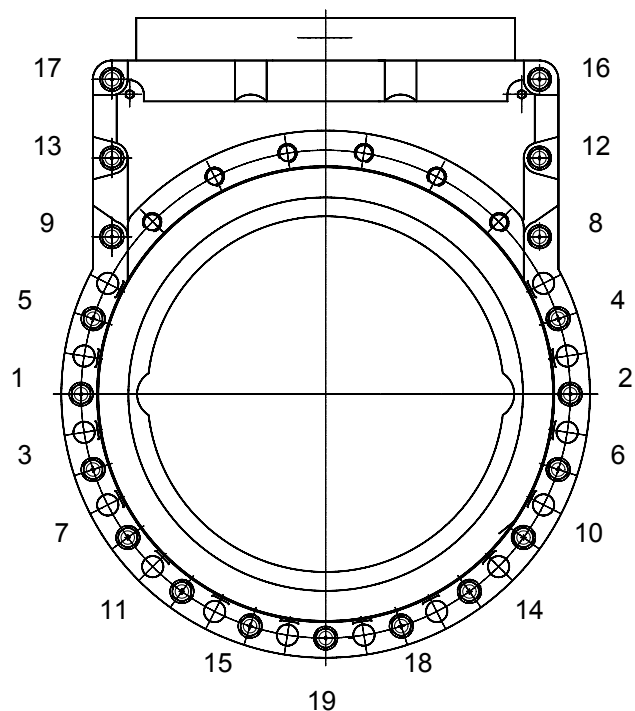

7. Packing

Fill packing material $\varnothing 4\text{mm}$ (B) into the two packing holes (M6 in the front body part) using the packing tool (C) until the bore hole is filled.
Then screw in the screws (A).

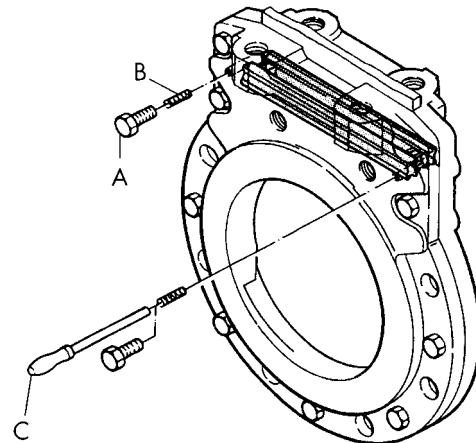

8. Pressure test

Before the valve is remounted in the pipeline, we recommend carrying out a pressure test.

We reserve the right to make changes and improvements.

status: 2005-03-31