

Maße/Dimensions

Schieber Serie AT 200 R mit E-Antrieb

Knife gate valve series AT 200 R

with electric actuator

DN 350 – DN 1200

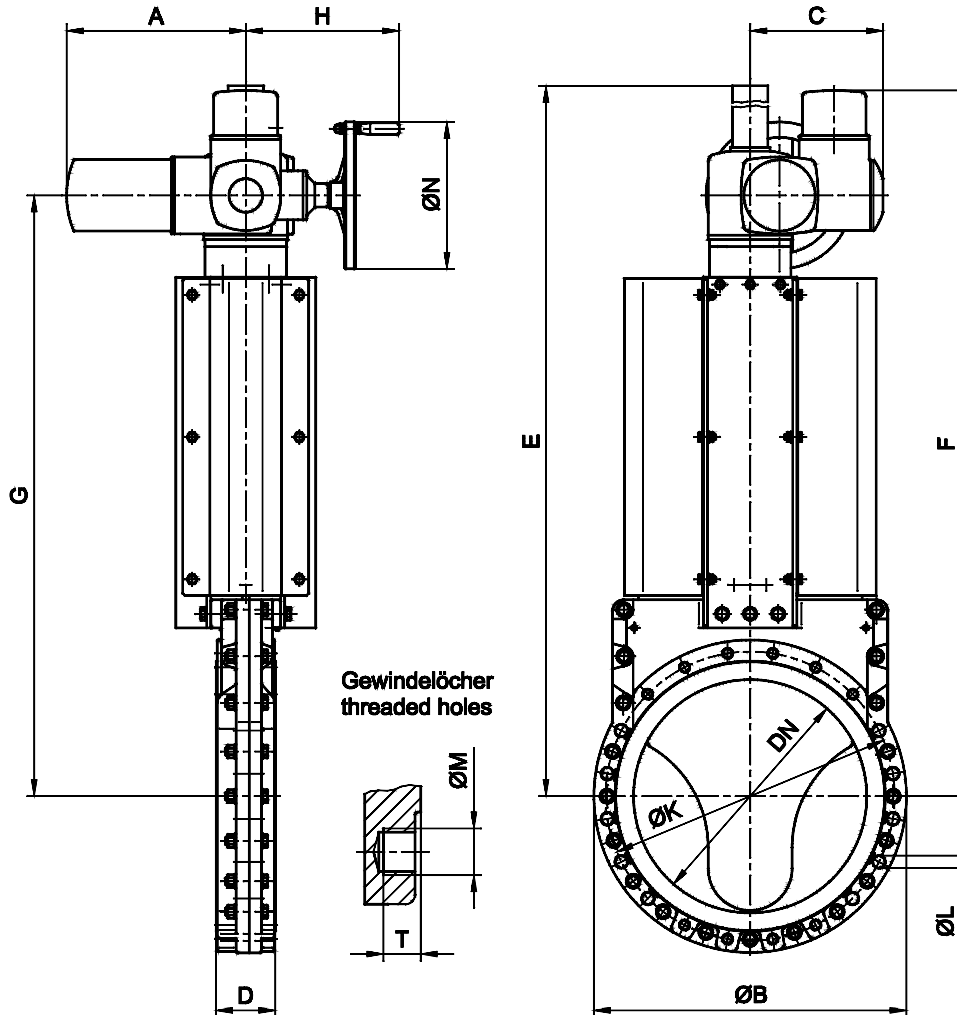

DN	NPS	Antrieb actuator	PB	A	ØB	C	D	E	F	G	H	ØK	ØL	ØM	T	ØN	kg
350	14"	SAR 10.1	6	282	505	247	78	1369	1226	1031	254	460	8xØ22	8xM20	18	200	165
400	16"	SAR 10.1	6	282	565	247	102	1455	1262	1067	254	515	8xØ27	8xM24	26	200	205
450	18"	SAR 14.1	4	384	615	285	114	1660	1462	1257	329	565	10xØ27	10xM24	26	315	275
500	20"	SAR 14.1	4	384	670	285	127	1741	1513	1288	329	620	10xØ27	10xM24	26	315	325
600	24"	SAR 14.5	4	384	780	285	154	1994	1666	1441	336	725	10xØ30	10xM27	35	400	470
700	28"	SAR 16.1	4	510	895	307	165	2340	1942	1717	354	840	12xØ30	12xM27	39	500	770
800	32"	SAR 16.1	4	510	1015	307	190	2625	2127	1902	354	950	12xØ33	12xM30	49	500	1050
900	36"	SAR 16.1	3	510	1115	307	203	2991	2393	2168	354	1050	14xØ33	14xM30	43	500	1420
1000	40"	SAR 16.1	2,5	510	1230	307	216	3251	2553	2328	354	1160	14xØ36	14xM33	45	500	1700
1200	48"	SAR 25.1	2	520	1455	366	254	3840	2878	2720	405	1380	16xØ39	16xM36	55	400	2600

Maße bezogen auf AUMA Standard-Stellantrieb. Geänderte Maße bei anderem Antriebstyp.
 Dimensions based on AUMA standard electric actuator. Dimensions change if other actuators are used.

PB [bar] = max. Betriebsdruck / max. working pressure

Max. Differenzdruck bei Betätigung / max. differential pressure during operation: 1 bar

Änderungen vorbehalten
 subject to changes