

Габариты Заслонка серии K18 Dimensions butterfly valve series K18 DN 350 – DN 500

Монт. длина: EN 558-1 Reihe 20 (DIN 3202-K1) Face to face dimension: EN 558-1 line 20 (DIN 3202-K1)
 Монтажный фланец: ISO 5211 Mounting plate: ISO 5211

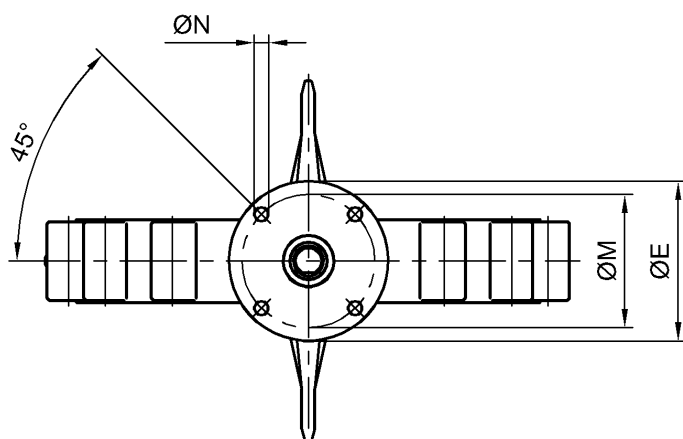
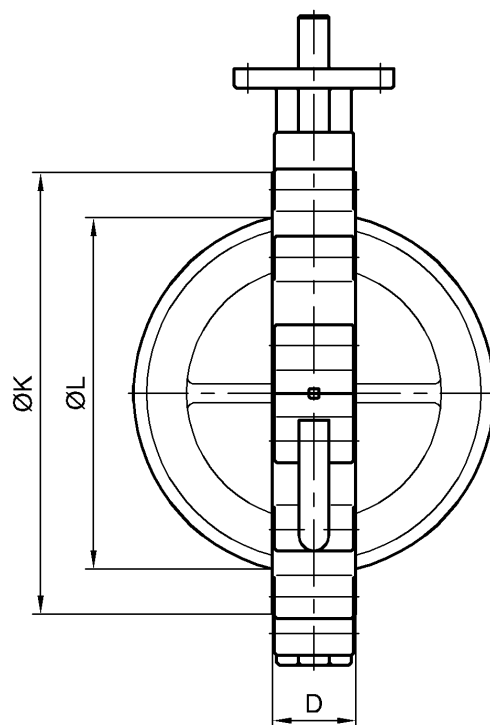
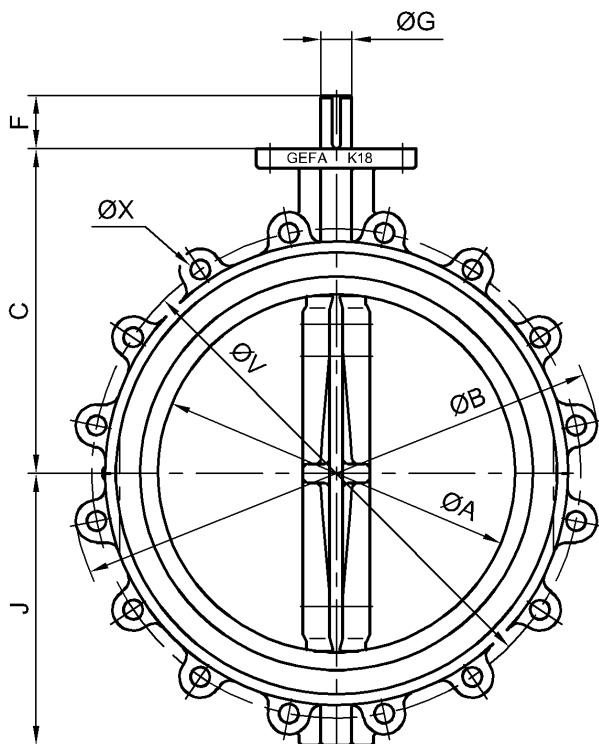

DN	NPS	PN10	
		ØV	ØX
350	14"	460	16 x M20
400	16"	515	16 x M24
500	20"	620	20 x M24

ØK = внешний диаметр седельного кольца
 Seat outside diameter

ØL = мин. внутренний диаметр фланца
 smallest inside diameter of flange

DN	NPS	ØA	ØB	C	D	ØE	F	ØG	J	ØK	ØL	Шпонка Key DIN 6885	Монтажный фланец Mounting plate			kg
													ØM	ØN	ISO 5211	
350	14"	337	500	305	78	150	50	29	255	415	330	8 x 7	125	4 x Ø13	F12	54
400	16"	387	585	330	102	150	60	40	285	469	377	12 x 8	125	4 x Ø13	F12	82
500	20"	490	685	403	127	203	60	50	352	571	475	14 x 9	165	4 x Ø22	F16	193